

7' x 7' L-Screen Assembly (shown with optional pad kit)

STEP 1:

Assemble frame and base using hardware provided.

STEP 2:

For maximum frame stability, face the large 1" hole opening on the **frame components** towards the interior of frame. The nut and washer are attached through the large hole opening (Figure A).

STEP 3:

Slip pillowcase net over frame and secure bottom sewn rope borders to **frame** using zip ties **provided**.

Disregard Steps 4&5 if optional pad kit not purchased.

STEP 4:

Assemble pre-cut foam pads as shown (if purchased). Trim pads as required. Use excess padding to fill in corners.

STEP 5:

Starting at one end, attach vinyl banner to foam padding using zip ties. Seam to be located on interior of frame.

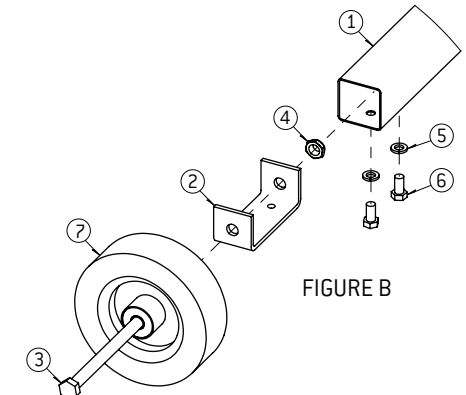
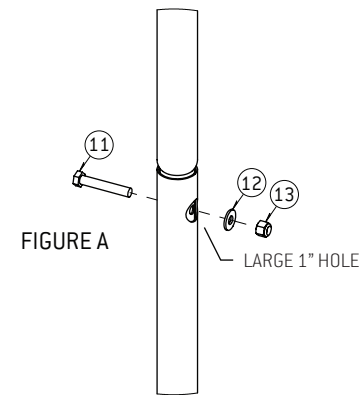
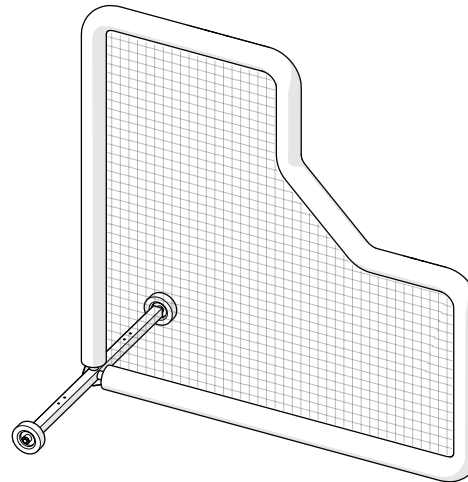

ITEM NO.	DESCRIPTION	QTY.
1	SCREEN BASE	1
2	WHEEL KIT AXLE BRACKET	2
3	1/2"-13 X 7 1/2" HEX BOLT (PARTIAL THREAD)	2
4	1/2"-13 JAM LOCK NUT	2
5	3/8" X .68" OD SPLIT LOCK WASHER	4
6	3/8"-16 X 3/4" HEX BOLT	4
7	6" X 2" FLAT FREE TIRE	2
8	LONG FRAME TUBE	2
9	U-BRACE	2
10	45-DEGREE CONNECTOR	1
11	3/8"-16 X 2 1/4" HEX BOLT (PARTIAL THREAD)	6
12	5/16" X .875" OD WASHER	6
13	3/8"-16 LOCK NUT	6
14	PAD A [43" L W/ [1] CUT ON SEAM]	4
15	PAD B [48" L]	2
16	PAD C [29" L W/ [2] CUTS OPP. SEAM]	1
--	7' X 7' L-SCREEN NET	1
--	VINYL GROMMETED PAD COVER	1
--	8" ZIP TIE PACK OF 100 (NOT SHOWN)	1

