

# ***streamliner***

**DRYLINE MARKER™**

*& Double Play Attachment*

## **ASSEMBLY & USAGE GUIDE**

*Streamliner 70 and Streamliner 353*



**BEACON<sup>®</sup> ATHLETICS**

# streamliner

DRYLINE MARKER™

Your new Streamliner was shipped partially assembled and requires some minor assembly — to the wheels and handle. Assembly only takes a few minutes.

■ **Identify your Streamliner model:**

- A. Streamliner 70 — **4 wheels**, 70 lb chalk capacity
- B. Streamliner 353 — **3 wheels**, 35 lb chalk capacity

The assembly is the same for the rear wheels and retractable handle, regardless of which model you have. Assembly for the front wheel(s) is described on the following pages for the 3-wheel and 4-wheel models.

*NOTE: For a two-wheel option, do not add the front wheel to the Streamliner 353 model (example shown below, far left).*



*Streamliner two-wheel option\**

*Streamliner 353*

*Streamliner 70*

**Your satisfaction is our ultimate goal.**

Please contact us online at [BeaconAthletics.com/contact-us](http://BeaconAthletics.com/contact-us)  
or call 800-747-5985 if you have any questions.



# All Models | Rear Wheels & Handle

## ASSEMBLY INSTRUCTIONS

Rear wheel assembly is the same for both Streamliner models.

### • REAR WHEELS

**Tools needed:** standard pliers

- 1 Locate the parts needed for assembly.
  - 2 no-flat drive tires\*
  - 2 cotter pins
- 2 Place the hub of the first drive tire over the axle.
- 3 Align the holes in the wheel hub and axle and insert cotter pin as shown.
- 4 Bend both sides of the cotter pin to secure in place.
- 5 Repeat steps 2-4 for assembling the second tire.

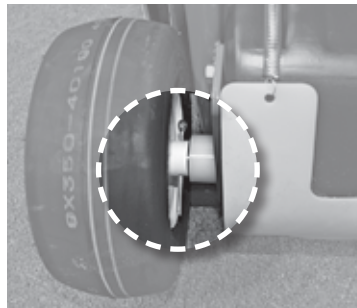

\*NOTE: Drive tires include a crosscut hole in the long hub for a cotter pin.

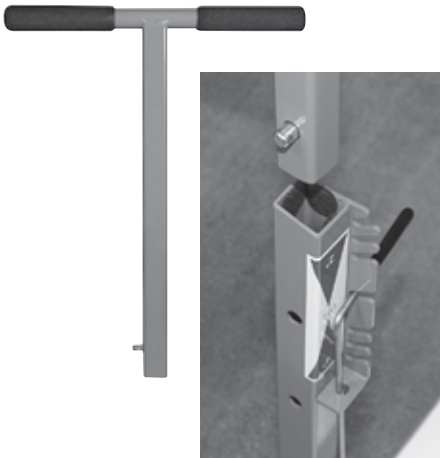

### • RETRACTABLE HANDLE

**Tools needed:** none

- 1 Locate the handle for assembly.
- 2 Align the push button on the handle stem with the holes located on the handle already on the Streamliner.
- 3 Gently insert the handle assembly into the handle on the Streamliner.
- 4 Slide the handle to the desired position until the push button snaps into place.  
**When storing,** push the button and slide the handle all the way down to the last hole.

If you prefer a 2-wheel Streamliner, your assembly is complete.

Continue to "Operation" on page 8.

# Streamliner 353 | Front Wheel

## ASSEMBLY INSTRUCTIONS

**3-wheel Streamliner 353 ONLY** (for 4-wheel model wheel assembly, go to page 6)

### • FRONT WHEEL

#### Tools needed:

two 3/4" wrenches

- 1 Locate the parts for front wheel assembly.
  - 1 no-flat tire
  - 1 axle bolt and nut
  - 1 large wheel spacer
  - 1 small wheel spacer
  - 2 1/2" washers
- 2 Thread axle bolt through 1/2" hole on the front of the frame that extends ahead of the Hopper.
- 3 With the axle bolt through the hole, add the large wheel spacer, followed by a washer to the axle.
- 4 Add the no-flat tire to the axle so the flat side of the tire hub is next to the first washer (figure 1, right).
- 5 Push axle bolt through the tire and add washer, then slide the small wheel spacer onto the axle bolt (figure 2, right).
- 6 Push the axle through the 1/2" hole on the other side of the frame and attach the axle nut.
- 7 Using a 3/4" wrenches, secure the nut to the axle bolt.  
**DO NOT OVER TIGHTEN.** Make sure the tire rotates freely.

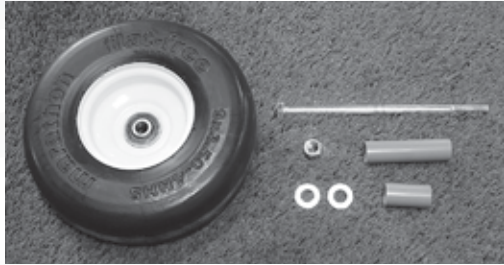

**This completes assembly for the 3-wheel Streamliner 353.**

Continue to "Operation" on page 8.



figure 1

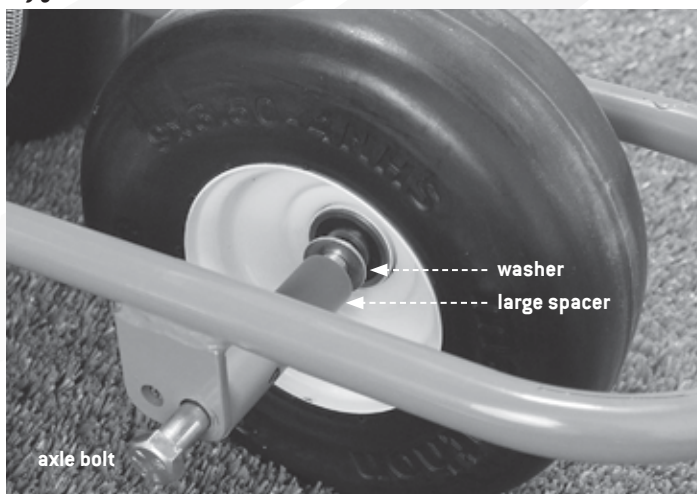
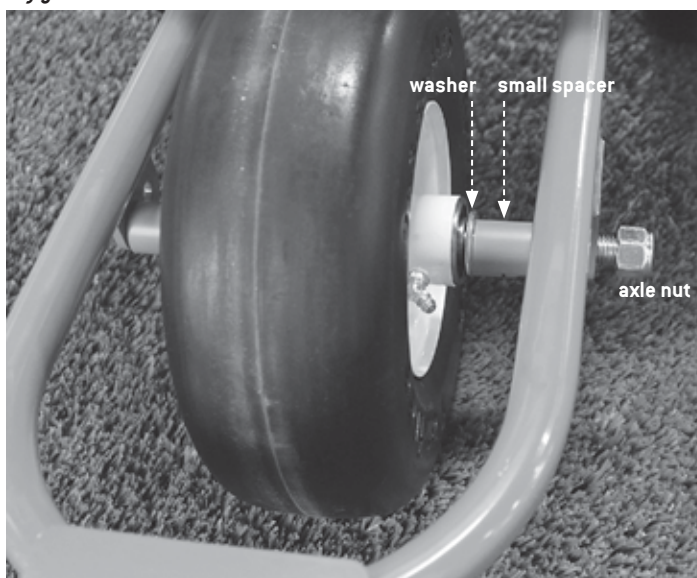

figure 2



# Streamliner 70 | Front Wheels

## ASSEMBLY INSTRUCTIONS

**4-wheel Streamliner 70 ONLY** (for 3-wheel model wheel assembly, see previous page)

### • FRONT WHEELS

#### Tools needed:

Two 3/4" wrenches

- 1 Locate the parts for front wheel assembly.
  - 2 no-flat tires
  - 1 axle cover
  - 1 axle bolt and nut
- 2 Thread the axle bolt through one no-flat tire hub (extended portion of the hub is designed to go toward the frame) as shown in figure 1.
- 3 Push the axle bolt through the 1/2" hole on the front frame that extends forward from the hopper.
- 4 Slide the axle cover over the axle bolt (figure 2).
- 5 Push axle bolt through the other 1/2" hole on opposite side of frame.
- 6 Slide the second no-flat tire onto the axle bolt (remember, extended hub portion toward the frame).
- 7 Attach the axle nut and using your 3/4" wrenches, secure the axle nut to the axle bolt. **DO NOT OVER TIGHTEN.** Make sure the tire rotates freely.

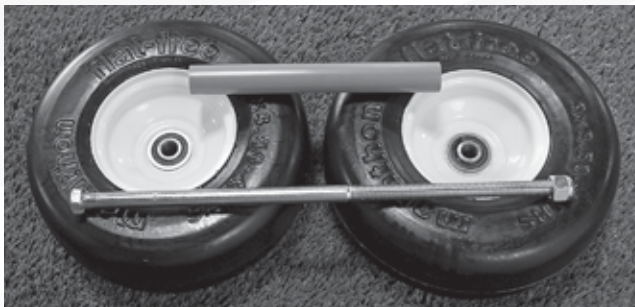

**This completes assembly for the 4-wheel Streamliner 70.**

*Continue to "Operation" on page 8.*

figure 1

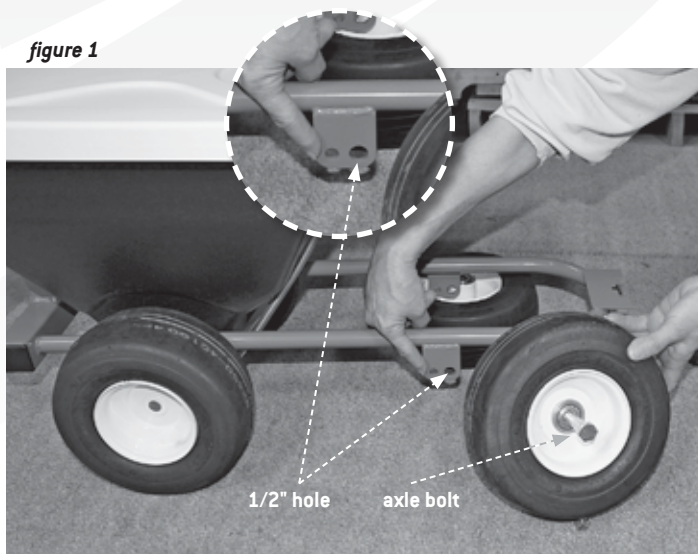
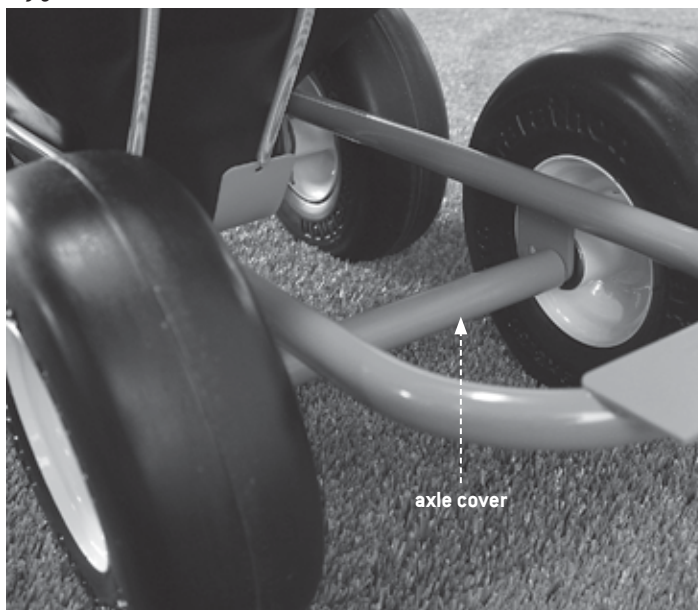

figure 2



# All Models | Using Your Streamliner

## OPERATION

### USING THE TELESCOPING HANDLE

All Streamliners have a collapsible handle that measures 29" in height and fits easily inside an on-site storage box.

**To extend the handle,** press the chrome spring button in on the side of the handle near the bottom. Pull up slowly on the handle until the chrome spring-button pops into the retaining hole near the top of the bottom half of the handle.

**To retract the handle,** simply depress the button and push the handle back down into the lower half until the button pops into the bottom hole.

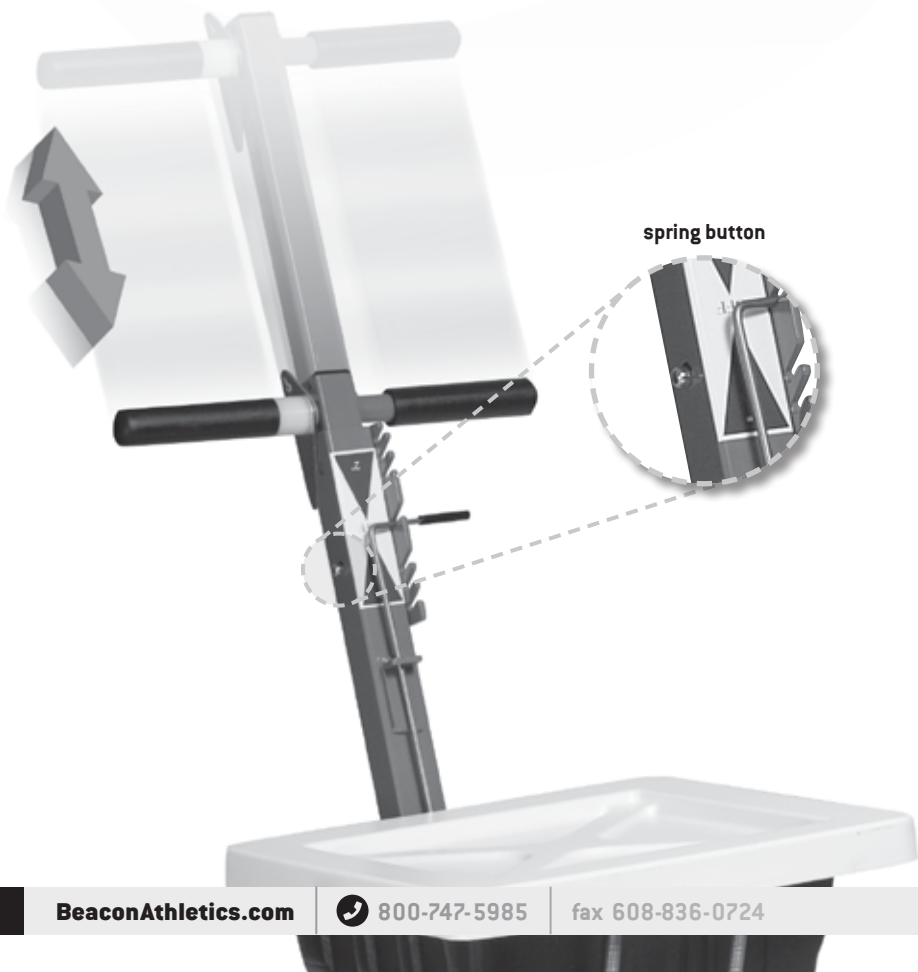

spring button



## USING THE VARIABLE FLOW CONTROL

The Streamliner's Variable Flow On/Off Control gives you total command of the flow of your dryline material. Some dryline material will flow rapidly while others flow more slowly and can "bridge" within the hopper.

With this in mind, the **Variable Flow Control** was designed for the operator to adjust the opening according to each material's flow rate.

**The off position is in the center.** Move the spring-loaded lever upwards to mark a 2" line and downwards for a 4" line. The further away from the off position you get, the wider the opening gets for chalking material to flow through.

Three preset notches on both the 2" and 4" end of the control allows the operator to lock in the chalk flow and adjust on the fly, as necessary.

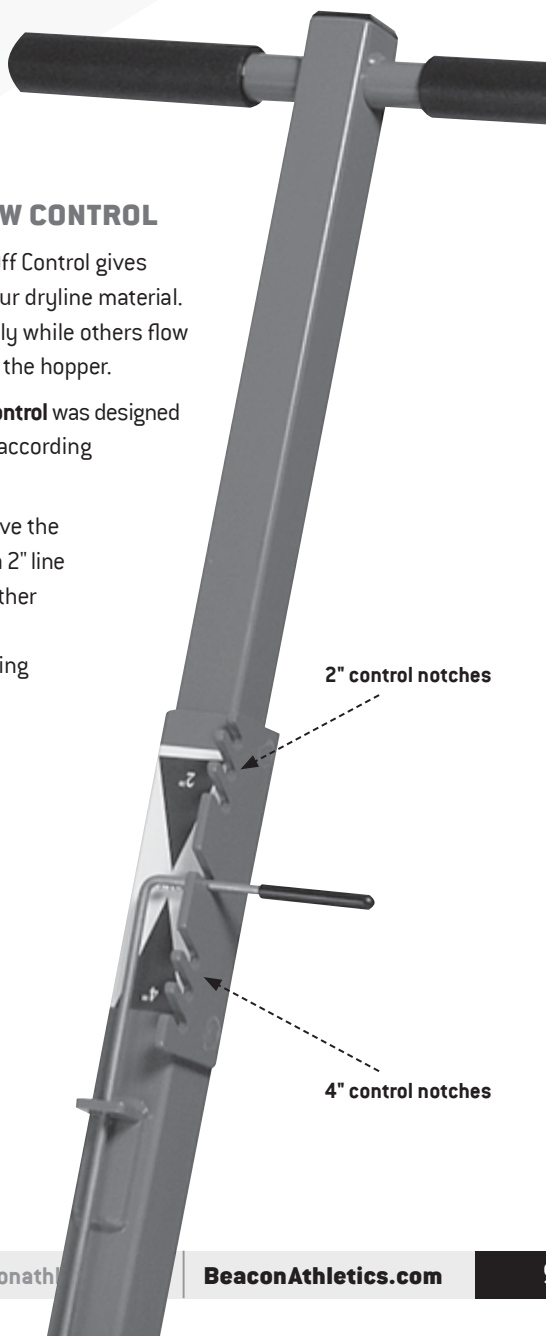

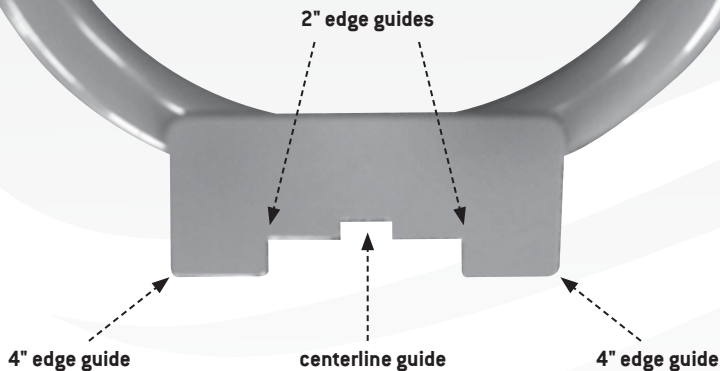

### USING THE WELDED ALIGNING GUIDE

There are **five guide marks** welded to the front of the Streamliner frame (above, all models). The guide provides a center notch as well as edge guides for either edge of the 2" and 4" lines. Simply lay out a stringline and the Streamliner's guide will help you maintain accurate alignment.

## HOPPER CAPACITY

### 3-WHEEL STREAMLINER 353

Hopper holds between 35 - 40 pounds of dry line marking material.

---

### 4-WHEEL STREAMLINER 70

Hopper holds between 70 - 75 pounds of dry line marking material.

## REGULAR MAINTENANCE

*Both models*

**If your Streamliner will sit idle for a month or longer, the hopper should be emptied completely.** To empty the hopper, simply open the hopper cover and tip the unit over a large bucket. Spin the wheels to help remove any material that is clinging to the flexible brush agitator.

A more thorough cleaning is needed at the end of the season or if the Streamliner will be idle for several months. Empty the hopper first, then return the Streamliner to its normal position. Move the Variable Flow Control lever to the widest 4" line notch.

Use a hose to thoroughly spray the entire unit with water — including the hopper — inside and out. Be sure to rotate the brush agitator as you spray the interior of the hopper by rolling the Streamliner forward.

*Be sure to allow the Streamliner to dry thoroughly before using it again.*

# Parts List | Parts Diagram

3 - W H E E L 3 5 3

*Checkmarks identify parts included with Refurbishing for Kit 353 (240-100-350).*

✓ 1	Hopper Cover	✓ 11	[2] Inner Bearings
2	Chalk Hopper	✓ 12	[3] Cotter Pins
3	[2] Clevis Pins	13	Lower Handle and Frame
✓ 4	[2] Large Springs	✓ 14	Brush Agitator
✓ 5	Mask	15	Control Rod
6	Welded Aligning Guide	16	Slug Pin
7	Front Wheel Kit	17	Upper Handle
8	[2] Rear Drive Wheels	18	[2] Handle Grips
9	Rear Wheel Axle	19	Double Play (Optional)
✓ 10	[2] Outer Bearings		

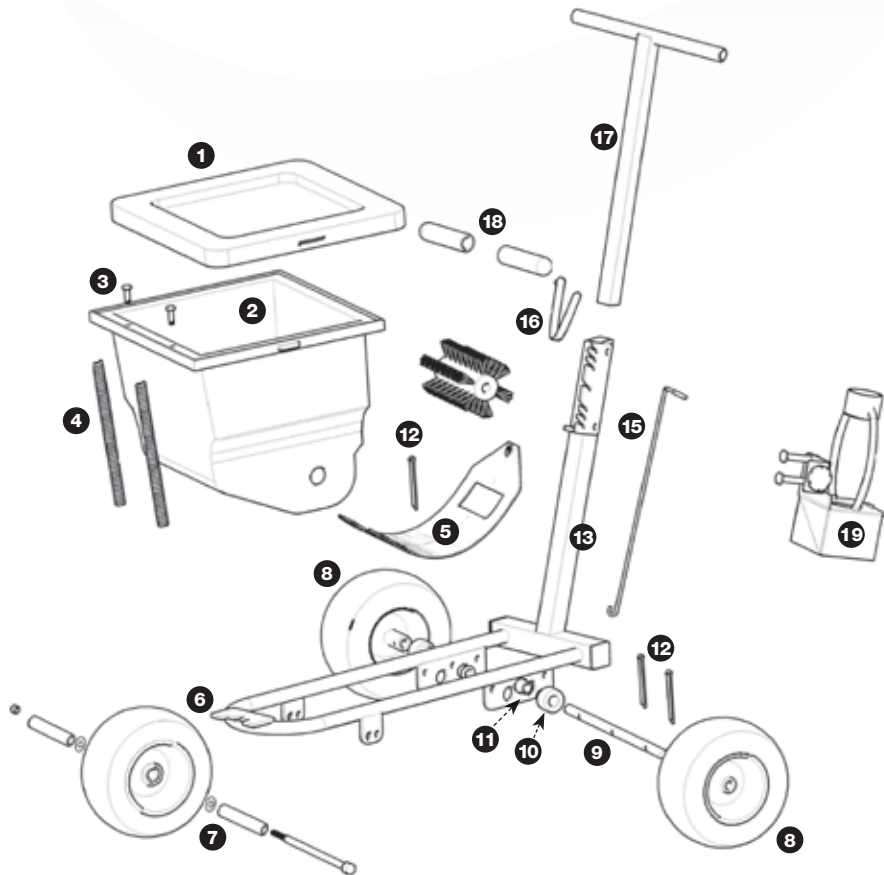

## 4 - W H E E L 7 0

*Checkmarks identify parts included with Refurbishing for Kit 70 (240-100-700).*

<b>1</b>	Hopper Cover		<b>12</b>	Axle
<b>2</b>	Chalk Hopper		✓ <b>13</b>	[2] Outer Bearings
<b>3</b>	[2] Clevis Pins		✓ <b>14</b>	[2] Inner Bearings
✓ <b>4</b>	[2] Large Springs		✓ <b>15</b>	[3] Cotter Pins
✓ <b>5</b>	[2] Small Springs		<b>16</b>	Control Rod
✓ <b>6</b>	Mask		<b>17</b>	Lower Handle and Frame
<b>7</b>	Welded Aligning Guide		✓ <b>18</b>	Brush Agitator
<b>8</b>	[2] Front Wheels		<b>19</b>	Slug Pin
<b>9</b>	[1] Axle Bolt with Nut		<b>20</b>	Upper Handle
<b>10</b>	Front Axle Cover		<b>21</b>	[2] Handle Grips
<b>11</b>	[2] Rear Drive Wheel		<b>22</b>	Double Play (Optional)

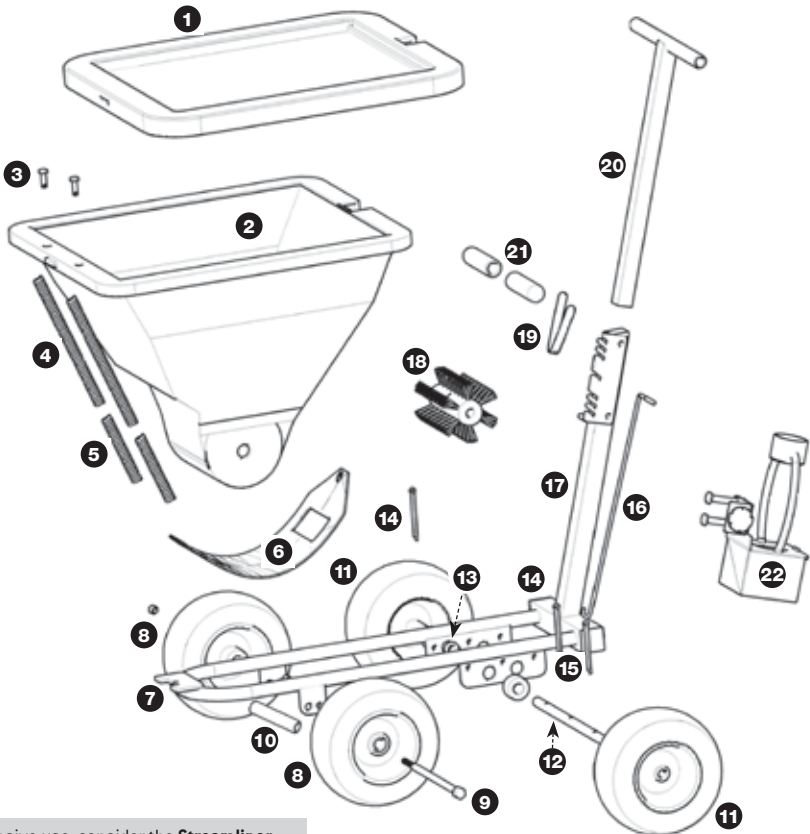

After extensive use, consider the **Streamliner Replacement Kits**. Replacing certain parts will restore any of these models to like-new condition.

# Double Play | Aerosol Attachment

## ATTACHMENT INSTRUCTIONS

*3-wheel 353 model and 4-wheel 70 model*

The optional **Double Play** connects to the vertical shaft of the Streamliner handle. If your Streamliner came with the Double Play already attached, skip to **Step 5** for set-up instructions.

**1 Remove the right handle grip** on the Streamliner and insert the trigger onto the handle shaft. The longest side of the triangle shaped trigger should face toward the front of the Streamliner chalker unit and the small slotted hole should be on the bottom. Then, reinstall the handle grip.



**2 To attach Double Play** start by unscrewing the tension bolt (red knob) until the end of the bolt is flush with the inside of the unit.



**3 Wrap the Double Play** around the **vertical handle shaft** of the Streamliner so it nestles into the u-joint. The Double Play can be located anywhere on the lower end of the vertical handle shaft.



An adjustment for proper height will be made in *Step 6*. Retighten the tension bolt to hold it to the vertical handle shaft.

**4** Connect the trigger chain to the trigger on the handle. Slide chain through the larger hole on the trigger and pull the chain taught before locking it into the smaller hole.



**5** Insert well shaken aerosol field paint can into the Double Play. To properly position the can, make sure the T or H nozzle of the spray can is inserted so that it is perpendicular to the capsule shaped hole in the triggering mechanism below the unit. After properly aligning the can, secure it by pulling the bungee cap up over the can. Place the cap into the concave portion of the base of the spray can. **To operate the Double Play, press the trigger on the handle forward** with your right thumb or forefinger just enough to spray the paint.

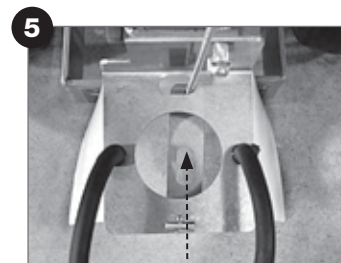

triggering mechanism

**6** Set your paint line width by spraying a test on turf that is mowed at the same height as your field turf. Loosen the compression screw and the trigger chain and adjust up or down until you get the desired line width. Remember to adjust the trigger chain length each time the Double Play is moved up or down. Use a permanent marker to indicate the line size. Do this for each size line you will need to paint.

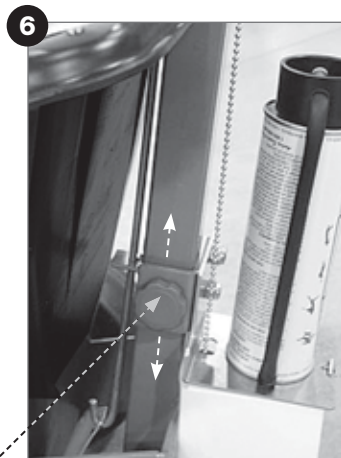

Loosen the compression screw upward for **wider lines** or downward for **narrower lines**

**Consider these Beacon Built field maintenance products ...**

**ADJUSTABLE WEIGHT DRAG SYSTEMS!**



**Beacon X-Drag Field Weight Kit**



**Beacon Adjustable Weight Nail Drag System**



**Get the weight right** with either the Beacon X-Drag Kit Field Kit or Adjustable Weight Nail Drag System. Both allow you to adjust the weight with Beacon Field Weights. The correct weight depends upon many factors, and field weights put you in control.

**LEVEL BOARD & SLOPE GAUGE**



**Beacon Level Board**



**Beacon Mound Slope Gauge**

**Improve your efficiency and accuracy** with these tried and true Beacon products. The Level Board lets you cover a much wider area to cut down high spots, making your leveling more effective and the heavy-duty aluminum Mound Slope Gauge gives you an accurate indication of your mound slope.

*Contact us or visit [BeaconAthletics.com](http://BeaconAthletics.com)*



**BeaconAthletics.com | 800-747-5985 | fax 608-836-0724 | Ballfields.com**

**8233 FORSYTHIA STREET, SUITE 120, MIDDLETON, WI 53562**

© Copyright 2016, Beacon Athletics, A division of Rainbow Group, LLC. All Rights reserved. This material may not be republished, rewritten or redistributed including electronically cached without the prior written consent of Beacon Athletics.

*Version 4 rev.2016-01*